



### TRACK

RC1301-2.0 Qty

**2 metres**  
Actual Length=2025mm (79 25/32")  
Hole Pitch=100mm (3 15/16")  
Fastening Slugs=21

RC1301-3.0 Qty

**3 metres**  
Actual Length=3025mm (119 3/16")  
Hole Pitch=100mm (3 15/16")  
Fastening Slugs=31

RC1301-6.0 Qty

**6 metres**  
Actual Length=6025mm (237 3/8")  
Hole Pitch=100mm (3 15/16")  
Fastening Slugs=61



### TRACK JOINER

RC1301J Qty



### TRACK FIXING SLUGS

RC00354 Qty

RC00360 Qty

RC00361 Qty

Slugs include M8 csk fasteners.  
See www.ronstan.com website for  
Track Fixing Slug Selection Table.



### LUFF GROOVE TRACK

RC1302-2.0 Qty

**2 metres**  
Actual Length=2025mm (79 25/32")  
Undrilled

RC1302-3.0 Qty

**3 metres**  
Actual Length=3025mm (119 3/16")  
Undrilled

RC1302-6.0 Qty

**6 metres**  
Actual Length=6025mm (237 3/8")  
Undrilled



### LUFF GROOVE TRACK JOINER

RC1302J Qty

<b>Hull LOA:</b>	Max. Monohull	23m (75')
	Max. Multihull	17m (56')

<b>Sail Area:</b>	Max. Monohull	120m <sup>2</sup> (1292ft <sup>2</sup> )
	Max. Multihull	93m <sup>2</sup> (1001ft <sup>2</sup> )

### Mast details (If known):

Spar Manufacturer	
Mast Type	
Profile No.	

### Mainsail details:

Luff Length (P)	
Foot Length (E)	
Qty. Full Length Battens	

## Track Series 30

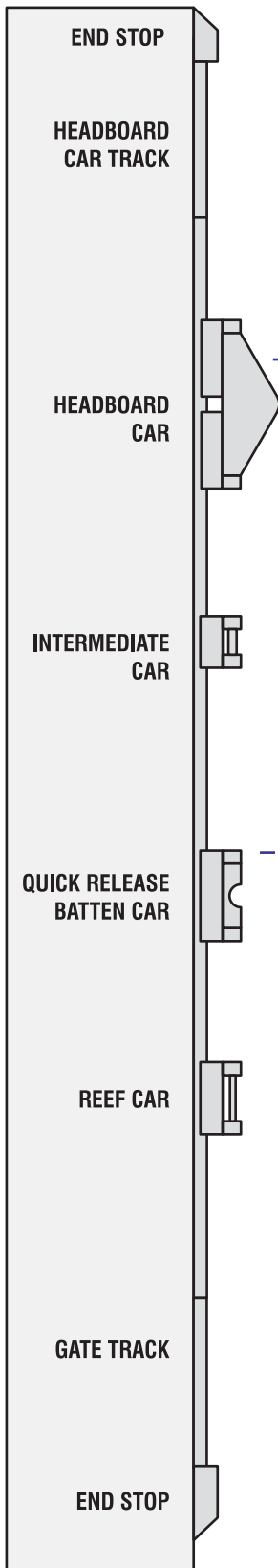

RC13080 Qty  
L=37mm (1 15/32")

RC1308-1.5 Qty \*

L=1500mm (59 3/32")  
Hole Pitch=37.5mm (1 15/32")  
Fastening Slugs=40

RC13060 Qty  
L=255mm (10 1/16")

RC13063 Qty  
L=78mm (3 1/16")  
Typically 6 per system

RC13069 Qty  
L=130mm (5 1/8")  
Typically 5 per system

RC13072 Qty  
L=130mm (5 1/8")  
(Replaces an Intermediate car at each reef point)

**Standard Gate Track**  
RC1309-0.3 Qty  
L=325mm (12 13/16")  
Hole Pitch=100mm (3 15/16")  
Fastening Slugs=4

**Luff Groove Gate Track**  
RC1309-0.3L Qty  
L=325mm (12 13/16")  
Undrilled

RC13081 Qty  
L=65mm (2 9/16")

RC00011 Qty  
RC00012 Qty (Small eyes)

### HEADBOARD PLATES (Pair)

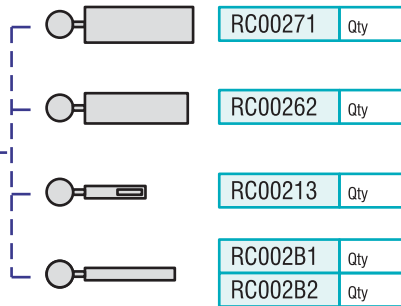
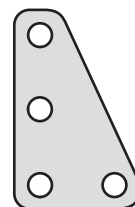

### QUICK RELEASE BATTEN RECEPTACLE LINKS

RC00271 Qty

RC00262 Qty

RC00213 Qty

RC002B1 Qty

RC002B2 Qty

\*Additional headboard track sections are sometimes required to take headboard loads when reefed. Please consult your sailmaker for recommendations.