

## MOUNTING INSTRUCTION WINCH 46, VER.1.2

1. Remove circlip (1), using a small sharp screw driver.
2. Remove drum (2).
3. Mark location of the bolt holes using the winch base (15) as a template.
4. Remove the winch base. Be sure that no dust comes into contact with the winch while drilling the bolt holes.
5. Drill the bolt holes  $\varnothing 8.5\text{mm}$ .
6. Clean the area.
7. Apply a light coat of bedding compound, ensuring that each hole is bedded. Drain grooves should be kept clear.
8. Fasten the winch base into place using 5 pcs M8 countersunk head screws.
9. Assemble in reverse order
10. Check that the winch is functioning correctly.

## SERVICE INSTRUCTION WINCH 46, VER.1.2

Maintenance interval 1-2 years, depending on operating conditions.

1. Remove circlip (1).
2. Remove drum (2).
3. Remove the black plastic circlip (8).
4. Remove drive shaft (6).
5. Remove roller bearings (7,9).
6. Remove gear shaft (10) using a standard screwdriver
7. Remove & dismantle the gear unit (11,12,13,14)
8. Clean all moving parts with benzine.
9. Check pawls & springs for wear and replace if necessary. In order to replace the upper pawls (4) or springs (5), the gliding washer (3) must be removed.
10. Reassemble the winch in reverse order, lightly greasing all moving parts, with a soft, small brush. We strongly recommend to use only ANDERSEN Winch Grease for this purpose\*
11. Check that the winch is functioning correctly.

*\*) Most types of grease, including "marine grease" are NOT suitable for lubrication of winches. None suitable grease can cause mechanical malfunction. Malfunctioning pawls may lead to unexpected failure of a loaded winch, resulting in material damage or fatal personal injury.*

**Service Kit No. 4 (part no. 710004) contains service parts for this winch.**

## PARTS LIST WINCH 46, VER.1.2

POS	QTY	DESCRIPTION	PART NO.
1	1	CIRCLIP	712800
2	1	DRUM	730500
3	1	GLIDING WASHER	718400
4	2	PAWL	533400
5	2	PAWL SPRING	533500
6	1	DRIVE SHAFT, COMPLETE	717700
7	1	ROLLER BEARING	712905
8	1	CIRCLIP	716001
9	1	ROLLER BEARING	712903
10	1	GEAR SHAFT	717900
11	1	PAWL GEAR	718100
12	2	PAWL SPRING	533500
13	2	PAWL	533400
14	1	RATCHET GEAR	718200
15	1	WINCH BASE	730400

## EXPLODED VIEW WINCH 46, VER.1.2

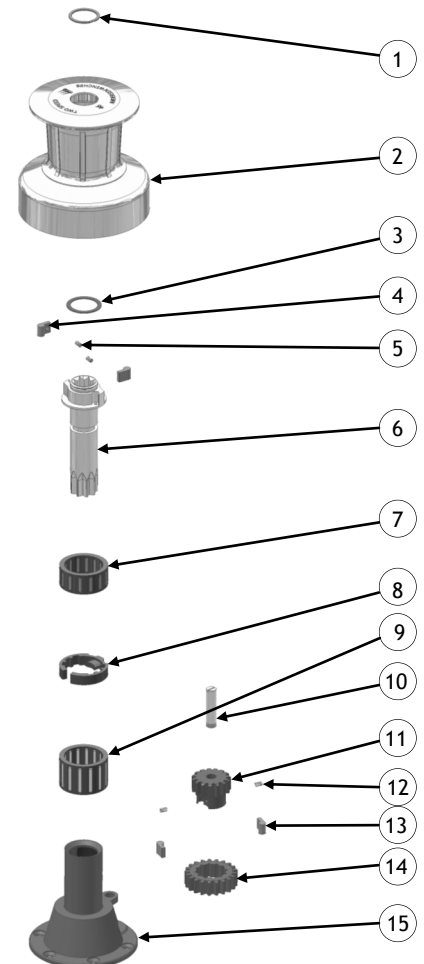

## WARRANTY

Refer to our website [www.ronstan.com/warranty](http://www.ronstan.com/warranty)  
for our warranty terms and conditions

## ALL WINCHES



### Read All Safety Notices and Product Manuals

Do not install or operate this winch before reading and fully understanding the contents of this Safety Notice Sheet and the Product Manual.



### Stay Alert When Operating

Andersen winches are very powerful and have the potential to cause significant damage and/or serious injury if used improperly or without due caution and vigilance.



### Operators Must Be Trained

Help prevent significant damage and/or serious injury by ensuring any person operating a winch has a thorough understanding of its proper operation and is aware of the potential hazards involved. As a minimum, all winch operators must read and understand this Safety Notice Sheet and the Product Manual. Particular attention is drawn to the following points:

- Children and others not qualified to operate an electric winch must be kept at a safe distance from the winch and any rigging or fittings that are under load.
- Long hair and/or loose clothing must be tied back to avoid being caught in the winch.
- In the event of a rope override or other fault, stop the winch and turn off power before attempting to resolve the problem.



### Avoid Accidental Operation

Remove winch handles and turn off power to the winch when not in use to help avoid unsupervised or unintentional operation. Failure to do so could result in significant damage and/or serious injury.



### Maintenance

Turn off power to the winch before performing any maintenance or service tasks. Failure to do so could result in significant damage and/or serious injury.



### Lifting Operations

The winch must not be operated with the rope in the self tailer when used in any kind of lifting operation.

Any lifting operations should be conducted by two persons in order to maintain constant visual contact with the object being lifted.

Furthermore the selftailer must not be used as a cleat for a rope used to lift or suspend any object. The rope must be secured properly by tying off, or leading to a suitable fitting such as a cleat or bollard.

Failure to observe these precautions could result in serious injury or death.

**DO NOT DISCARD**

Part nr. 710246, 9. februar 2012

## WORLD WIDE DISTRIBUTION & SERVICE

(FOR UPDATED DISTRIBUTOR LIST, PLEASE SEE  
[WWW.ANDERSENWINCHES.COM](http://WWW.ANDERSENWINCHES.COM))

Manual  
**WINCH 46**  
ver. 1.2

